



ISOMAG

The friendly magmeter

DATA SHEET

MV210



CE

ISOIL 
INDUSTRIA

INDEX

TECHNICAL DATA	3
OVERALL DIMENSIONS	4
MV210 EXPLODED LAYOUT	7
MAIN PAGES VISUALISATION	8
ELECTRICAL CONNECTIONS	9
DIGITAL INPUT	10
DIGITAL OUTPUTS	10
ANALOG OUTPUTS	11
FUNCTIONS MENU	12
ACCURACY	17
HOW TO ORDER	18

TECHNICAL DATA

OVERALL FEATURES	
Suitable For	<input type="checkbox"/> All the ISOMAG® sensors
Minimum conductivity	<input type="checkbox"/> 5 µS/cm
Altitude	<input type="checkbox"/> -200 m up to 4000 m
Ambient Temperature	<input type="checkbox"/> -20... +60°C / -4... +140 °F - Aluminium housing <input type="checkbox"/> -10... +50°C / 14... +122 °F - Reinforced Nylon
Humidity Range	<input type="checkbox"/> 0÷100%
STANDARD FEATURES	
Housing materials	<input type="checkbox"/> Painted Aluminium die casting <input type="checkbox"/> Nylon reinforced with 15% of fiber glass
Protection Rate	<input type="checkbox"/> IP 67
Power Supply/Consumption	<input type="checkbox"/> 100-240 V~ (20VA) – 44-66 Hz
Cable Gland	<input type="checkbox"/> N° 5 cable gland PG 11
Full scale value	<input type="checkbox"/> 0,4...10m/s
Dig. Input	<input type="checkbox"/> N°1 , programmable function (i.e. Totalizer reset)
Data Storage	<input type="checkbox"/> Values storing system in case of power failure
Galvanic Isolation	<input type="checkbox"/> All the inputs/outputs are galvanically isolated from power supply up to 250 V
Programming Plug In	<input type="checkbox"/> USB port for the connection to PC (USB cable type A/USB MINI B is required for the programming)
Bi-Directional	<input type="checkbox"/> Yes
Diagnostic Funct.	<input type="checkbox"/> Yes
Empty Pipe Detect.	<input type="checkbox"/> Yes
Batching Funct.	<input type="checkbox"/> Yes
CE Certification	<input type="checkbox"/> Yes
OPTIONAL FEATURES (CHECK HOW TO ORDER, AT LAST PAGE, FOR MORE DETAILS)	
Version	<input type="checkbox"/> Compact <input type="checkbox"/> Separate
Protection Rate	<input type="checkbox"/> IP 68
Conn. Sensor Cable	<input type="checkbox"/> CABLE C015/C016 for separate version
LCD Display	<input type="checkbox"/> Graphic display 128x64 pixels back light, 3 programming keys
Power Supply/Consumption	<input type="checkbox"/> Power supply : 100 ... 240 VAC 44/66 Hz <input type="checkbox"/> Power supply : 24 ... 36 VAC/VDC 0...45/66 Hz <input type="checkbox"/> Power supply : 12...48 VDC <input type="checkbox"/> Power supply : 100 ... 240 VAC 44/66 Hz + 1 Rechargeable Battery <input type="checkbox"/> Power supply : 24 ... 36 VAC/VDC 0...44/66 Hz + 1 Rechargeable Battery <input type="checkbox"/> Power supply : 12...48 VDC + 1 Rechargeable Battery
Outputs: Pulses/Frequence/Alarms/Batch	<input type="checkbox"/> N°1 digital Output , 1250 Hz, 100mA, 30 Vdc <input type="checkbox"/> N°2 digital Outputs , 1250 Hz, 100mA, 30 Vdc
Analog Output	<input type="checkbox"/> n° 1 Analogue output 0/4...20/22 mA (Hart optional) <input type="checkbox"/> n° 2 Analogue outputs 0/4...20/22 mA (Hart optional over Out.1)
Communication Gateway	<input type="checkbox"/> RS 485 <input type="checkbox"/> Wi-Fi (for programming)
Data Logger	<input type="checkbox"/> MicroSD Memory Card 4...32 GBytes
Protocols	<input type="checkbox"/> Modbus over RS 485 <input type="checkbox"/> HART (Available on analog output n° 1)
	
ACCURACY	
Measurements tolerance	<input type="checkbox"/> Flow rate (volume) = ±0,05% v.l. <input type="checkbox"/> Out 4/20 mA = ± 0,08 % v.l. <input type="checkbox"/> Frequency Out = ± 0,08% v.l.
Accuracy (whole system converter+- sensor)	<input type="checkbox"/> See table below

OVERALL DIMENSIONS

Compact version

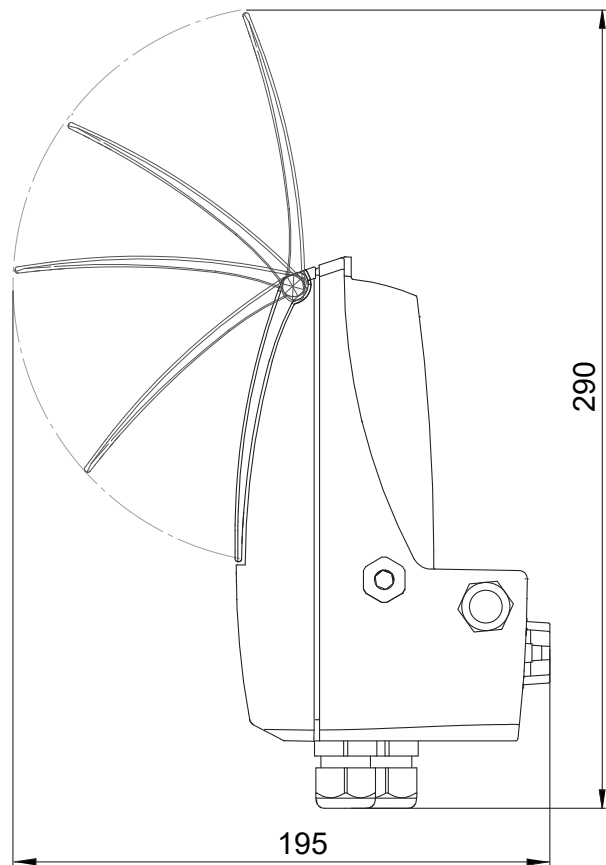
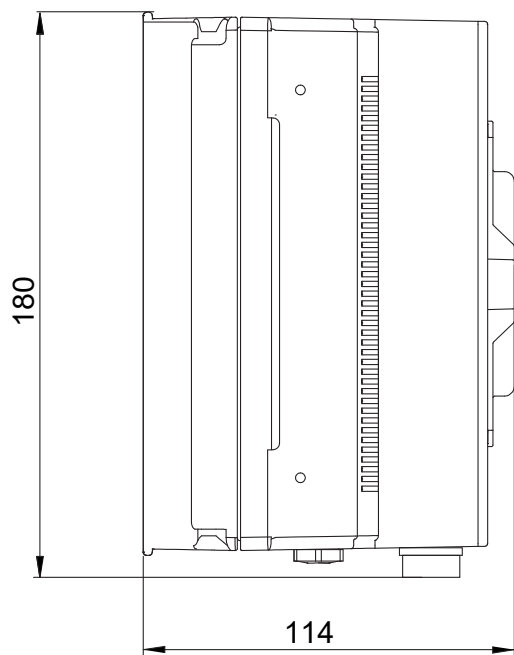
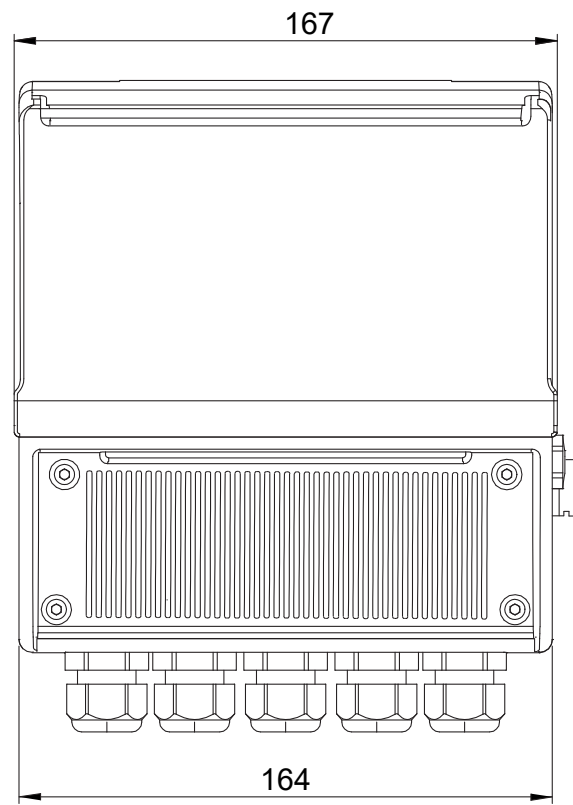
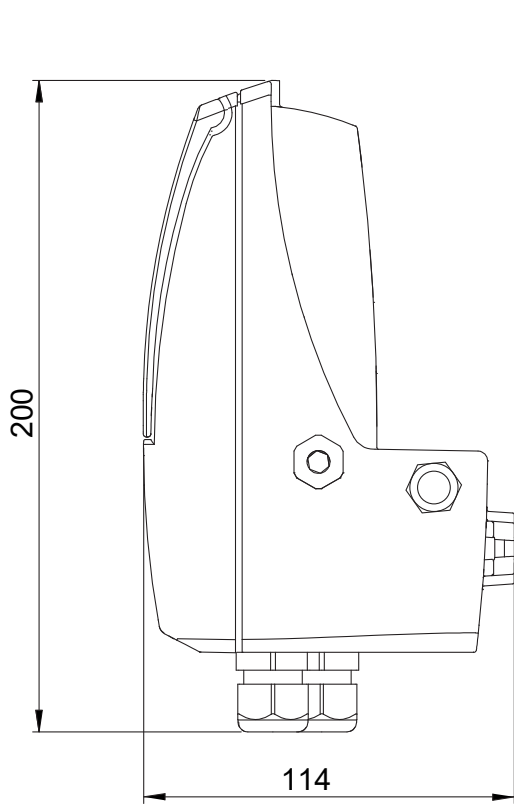

The manufacturer guarantees only English text available on our web site www.isoil.com

Separate (wall) version

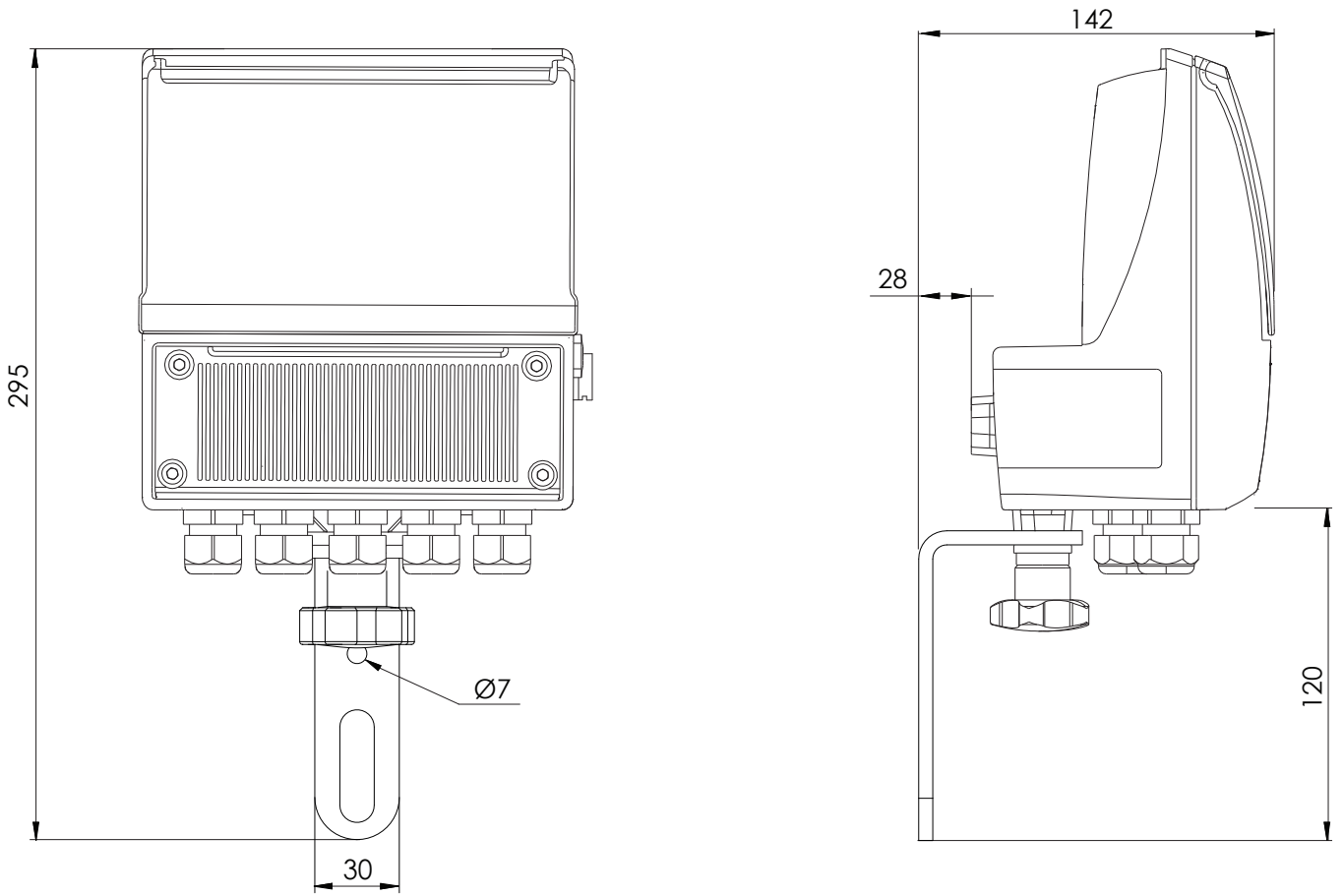

The manufacturer guarantees only English text available on our web site www.isoil.com

Horizontal version

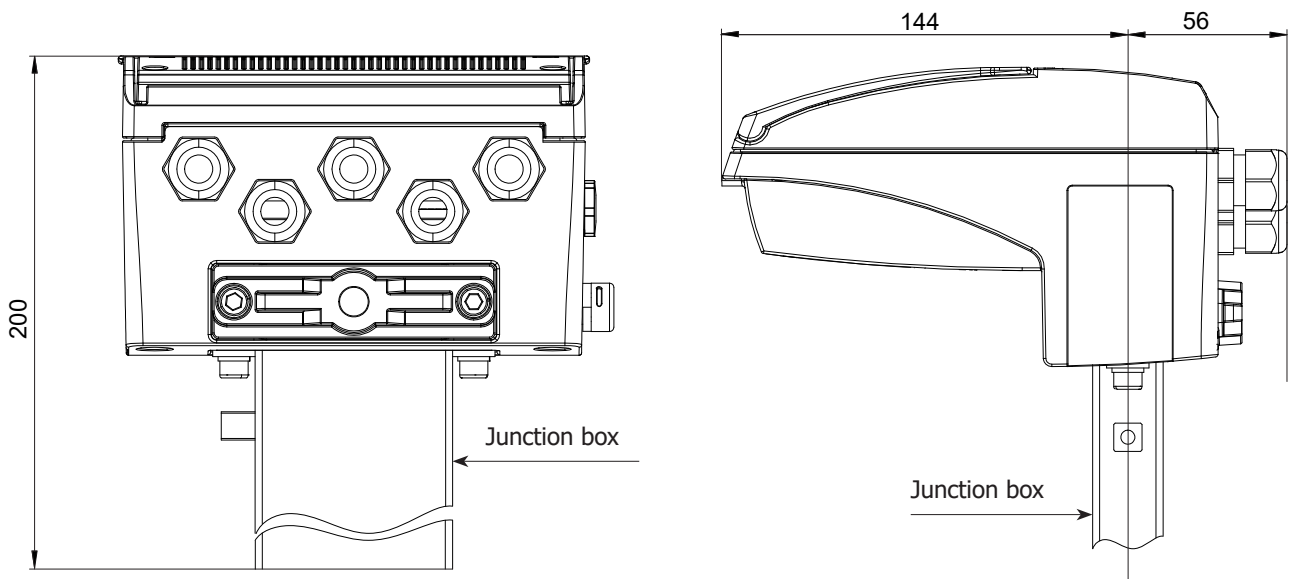

Vertical version

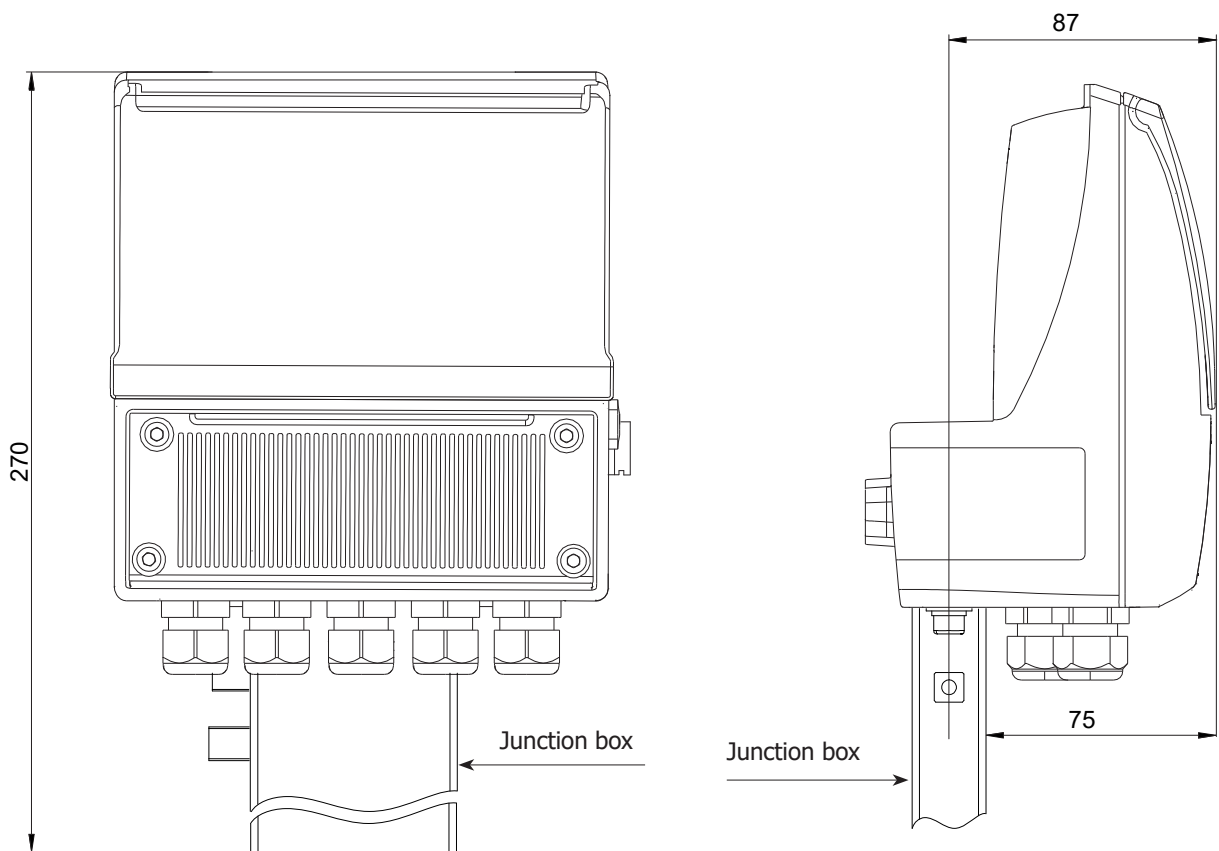

MV210 EXPLODED LAYOUT

POS.	DESCRIPTION	
	PA6 VERSION	ALUMINIUM VERSION
1	SCREW M4x12	SCREW M5x12
2	GROWER Ø4	GROWER Ø5
3	TERMINAL BLOCK COVER	TERMINAL BLOCK COVER
4	O-RING-4400	
5	PROTECTION COVER	
6	HOUSING COVER	HOUSING COVER
7	ORING-4700	
8	ORING-117x3	
9	DISPLAY	
10	FIXING DISPLAY FRAME (MATERIAL PA06)	
11	SELF-TAPPING SCREW 4x10	TRILOBO SCREW 4x10
12	SELF-TAPPING SCREW 4x10	TRILOBO SCREW 4x10
13	PCB MV210	
14	PG9 CAP	
15	LITHIUM BATTERY	
16	ANTICONDENSE CAP	
17	MAIN HOUSING	MAIN HOUSING
18	GROWER Ø4	GROWER Ø5
19	SCREW M4x12	SCREW M5x12
20	O-RING-155	
21	VERSION CAP (MATERIAL PA06)	
22	SCREW M6x16	
23	GROWER Ø6	
24	PG11 CABLE GLAND CABLE DIAMETER: Ø5-Ø10mm	
25	TERMINAL BLOCK SOLID WIRE: 26-16 AWG / 0.129-1.31 mm ² STRANDED WIRE: 26-16 AWG / 0.129-1.31 mm ² TORQUE: 3.0 Lb.In / 0.34 Nm	
26	DISPLAY FLAT CABLE	

Terminal block cover

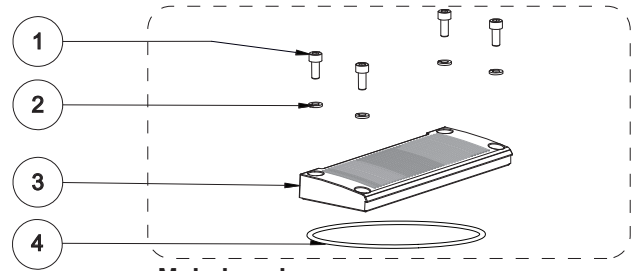

Main housing cover

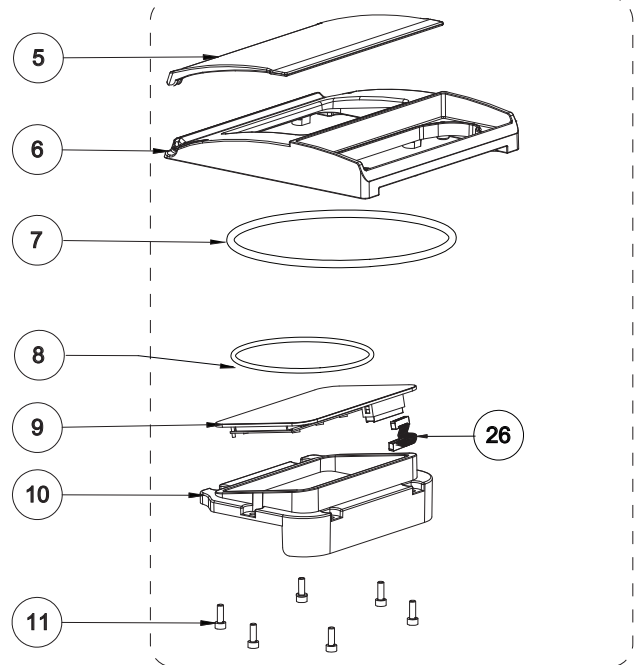

PCB MV210

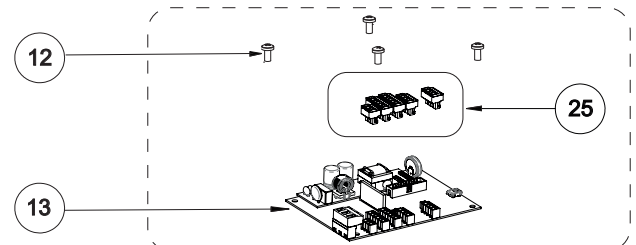

Main housing

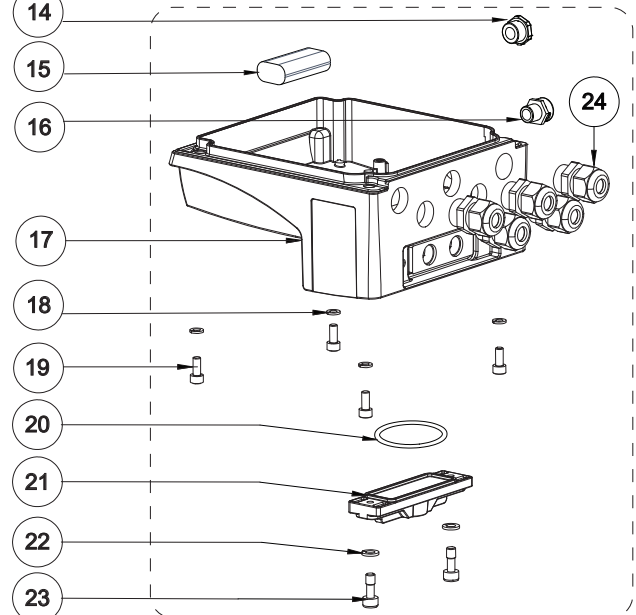

MAIN PAGES VISUALISATION

Different visualization possibilities by simply pressing of a key.

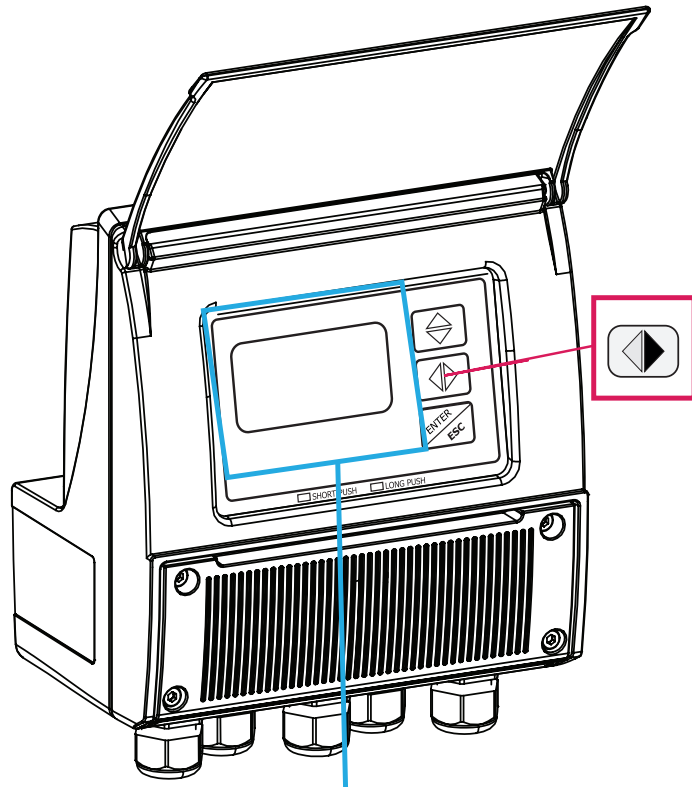

A vertical stack of six screen displays, each showing a different visualization mode:

- Screen 1:** Shows flow rate dm^3/s as **0.0000** and velocity m/s as **+0.000+**. Includes a graph with a y-axis from 0 to 100.
- Screen 2:** Shows flow rate dm^3/s as **0.0000** and velocity m/s as **+0.00%**. Includes a **3 ALARM(S)** indicator.
- Screen 3:** Shows flow rate dm^3/s as **0.0000** and cumulative volume $T+dm^3$ as **0.000**. Includes a **3 ALARM(S)** indicator.
- Screen 4:** Shows flow rate dm^3/s as **0.0000**. Includes a **3 ALARM(S)** indicator.
- Screen 5:** Shows cumulative volume $T+dm^3$ as **0.000**. Includes a **3 ALARM(S)** indicator.
- Screen 6:** Shows error messages: **3 ALARM(S)**, **CLOCK NOT SET**, **EXCITATION ERROR**, and **SIGNAL ERROR**.

The manufacturer guarantees only English text available on our web site www.isoil.com

ELECTRICAL CONNECTIONS

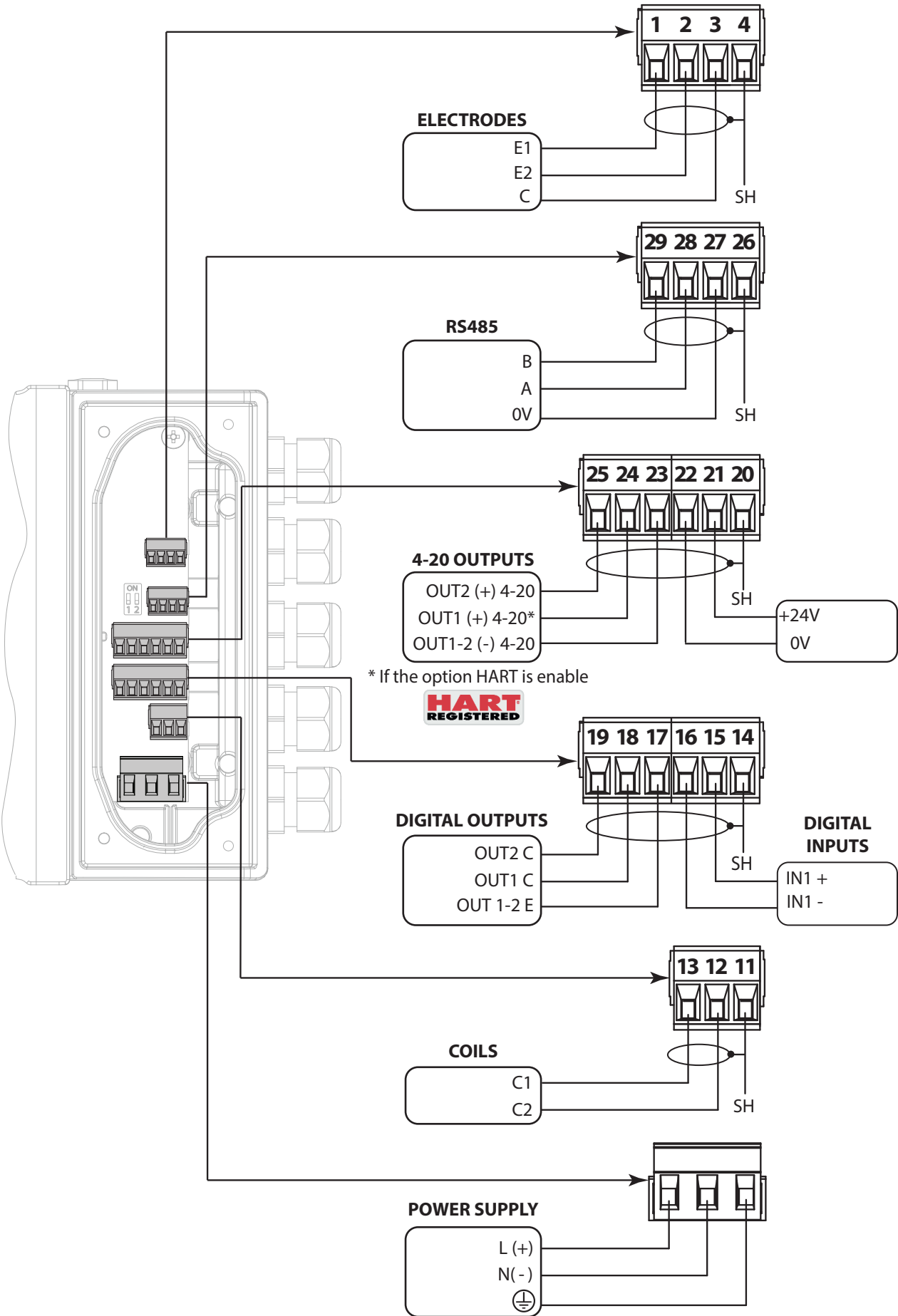

The manufacturer guarantees only English text available on our web site www.isoil.com

DIGITAL INPUT

on/off input
(external power supply)

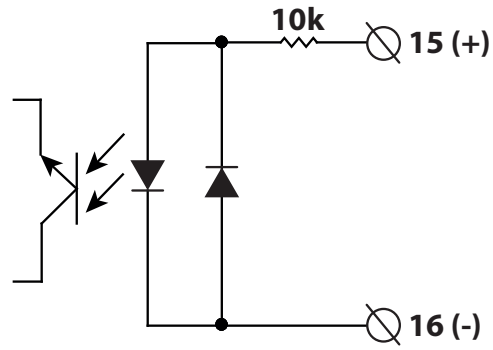

on/off input
(internal power supply)

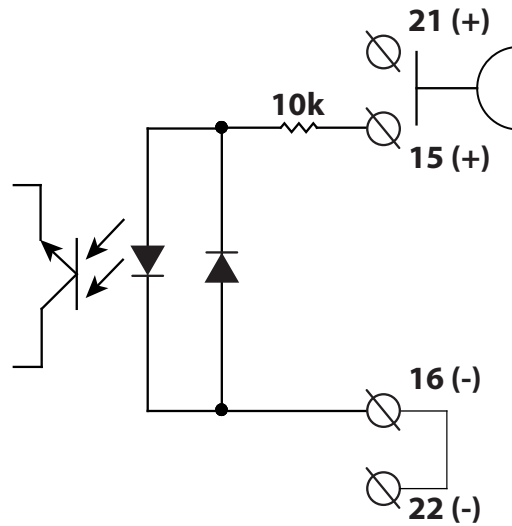

DIGITAL OUTPUTS

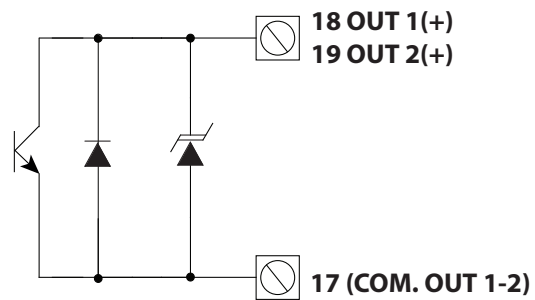

ANALOG OUTPUTS

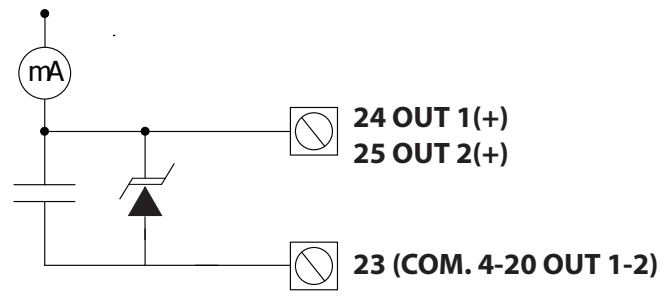

FUNCTIONS MENU

SENSOR

MAIN MENU		
1-Sensor		
SENSOR		
S. model =	0	1.1 Sensors model: Enter the first two characters of the serial number of the sensor
Lining =	UNSPEC.	1.2 Flow sensor lining material type
S. type =	FULL BORE	1.3 Type of sensor: fullbore or insertion
u.type=	METRIC	1.4 Type of measure units for sensor parameter: metric or imperial
Diam	mm 00025.0	1.5 Insert ND of sensor (0-2500)
HA =	+00.9637	1.6 Calibration data of sensor visualized on sensor's label
HA- =	-04.4904	1.7 Calibration data of sensor for negative flow
HZ =	+0000000	1.8 Sensor coefficient KZ (zero point)
HD=	+0000000	1.9 Sensor coefficient KD
Ins. position=	0	1.10 Insertion position
RP DinaWmic=	OFF	1.11 KP dynamic, coefficient for insertion
Ri=	01.8727	1.12 Sensor coefficient Ki
Kp=	01.0000	1.13 Sensor coefficient Kp
KC=	1.0000	1.14 Sensor coefficient KC
C.curr =	025.0	1.15 CW volume total, decimal point position
C.Reg.PB=	004	1.16 Current regulator proportional band
C.Reg.DR=	008	1.17 Current regulator derivation constant
S. Freq.= Hz	50	1.18 Measure sampling frequency
Preamplif.	OFF	1.19 Enables the preamplifier
E.P Detect=	ON	1.20 Enables the empty pipe detection feature
R max= kohm	0500	1.21 Empty pipe detection threshold
El. Cleaning=	OFF	1.22 Electrode cleaning
S. cable=	m 000	1.23 Sensor connecting cable length
S. err. delay=	010	1.24 Signal error delay (n. sample)
Sens. verify=	OFF	1.25 Automatic sensor verify enable
Zero point cal.		1.26 Pipe hydraulic zero calibration
KL	00.0000000	1.27 Linearization coefficient

UNITS

MAIN MENU		
1-Sensor		
2-Units		
3-Scales		
UNITS		
Diam.	mm	2.1 Nominal diameter measure unit
S.cable	m	2.2 Cable length on separate version
FR.unit	METRIC	2.3 Flowrate type measure unit: metric or not metric
PI1 unit	METRIC	2.4 Pulse 1 type measure unit: metric or not metric
PI2 unit	METRIC	2.5 Pulse 2 type measure unit: metric or not metric
T+ unit	METRIC	2.6 Total direct totalizer measure unit type: metric or not metric
T+ unit	g	2.7 Total direct totalizer measure unit
T+ D.P	3	2.8 Total direct totalizer decimal point position
P+ unit	METRIC	2.9 Partial direct totalizer measure unit type: metric or not metric
P+ unit	g	2.10 Partial direct totalizer measure unit
P+ D.P	3	2.11 Partial direct totalizer decimal point position
T- unit	METRIC	2.12 Total reverse totalizer measure unit type: metric or not metric
T- unit	g	2.13 Total reverse totalizer measure unit
T- D.P	3	2.14 Total reverse totalizer decimal point position
P- unit	METRIC	2.15 Partial reverse totalizer measure unit type: metric or not metric
P- unit	g	2.16 Partial reverse totalizer measure unit
P- D.P	3	2.17 Partial reverse totalizer decimal point position
Temp.unit	°C	2.18 Temperature measure unit
Mass units	ON	2.19 Enable/disable the selection of mass units on full scale set
Sg=kg/dm3	1.0000	2.20 Specific gravity coefficient

SCALES

```

MAIN MENU
1-Sensor
2-Units
3-Scales
4-Measure
5- Alarms
6-Inputs
7-Outputs
8-
9-
10-
11-
12-
13-
    
```

SCALES	
FS1 g/s	4908.7
B.qty dm3	1.00000
FS2 g/s	4908.7
Pls1=g	1000.00
Tpls1=ms	0050.0
Pls2=g	1000.00
Tpls2=g	0050.0
Frq1=Hz	1000.00
Frq2=Hz	1000.00

3.1	Full scale flow rate 1
3.2	Batching quantity
3.3	Full scale flow rate 2
3.4	Pulse value on channel 1
3.5	Duration of the pulse generated on channel 1
3.6	Pulse value on channel 2
3.7	Duration of the pulse generated on channel 2
3.8	Full scale frequency for channel 1 (0.1Hz-1000.0Hz)
3.9	Full scale frequency for channel 2 (0.1Hz-1000.0Hz)

MEASURES

```

MAIN MENU
1-Sensor
2-Units
3-Scales
4-Measure
5- Alarms
6-Inputs
7-Outputs
8-
9-
10-
11-
12-
13-
    
```

MEASURES	
Damping	SMART
Cut-off= %	00.1
DT Min.	ON
T1HC enable	ON
T1HC	OFF

4.1	Measure filter
4.2	Low flow zero threshold: 0-25% of full scale value
4.3	Automatic calibration verify
4.4	Automatic change of measurement range
4.5	High immunity inputs

ALARMS

```

MAIN MENU
1-Sensor
2-Units
3-Scales
4-Measure
5- Alarms
6-Inputs
7-Outputs
8-
9-
10-
11-
12-
13-
    
```

ALARMS	
Max+ = dm3/s	OFF
Max- = dm3/s	OFF
Min+= dm3/s	OFF
Min-= dm3/s	OFF
Hysteresis=%	03
mA v. alarm=%	000
Hz v. alarm=%	000

5.1	Maximum value alarm set for direct flow rate
5.2	Maximum value alarm set for reverse flow rate
5.3	Minimum value alarm set for direct flow rate
5.4	Minimum value alarm set for reverse flow rate
5.5	Hysteresis threshold set for the minimum and maximum flow rate alarms
5.6	Current output value in case of failure
5.7	Frequency output value in case of alarms

INPUTS

```

MAIN MENU
1-Sensor
2-Units
3-Scales
4-Measure
5- Alarms
6-Inputs
7-Outputs
8-
9-
10-
11-
12-
13-
    
```

INPUTS	
T+ reset	OFF
P+ reset	OFF
T- reset	OFF
P- reset	OFF
Count lock	OFF
Meas.lock	OFF
Calibration	OFF
Range change	OFF

6.1	Total direct (positive) flow totalizer reset enable
6.2	Partial direct (positive) flow totalizer reset enable
6.3	Total reverse (negative) flow totalizer reset enable
6.4	Partial reverse (negative) flow totalizer reset enable
6.5	Totalizer counting lock command
6.6	Measure zero lock command
6.7	Calibration external command
6.8	Range change external command

OUTPUTS

MAIN MENU		
1	Sensor	
2	Units	
3	Scales	
4	Measure	
5	Alarms	
6	Inputs	
7	Outputs	
8	Communication	
9	Display	
10	Data logger	
11	Functions	
12		
13		
OUTPUTS		
10	Out1	PULSES+
11	Out2	PULSES-
12	Out mA1	4_22 +/-
13	Out mA2	4_22 +/-
	A1S	4.9087
	A2S	4.9087

7.1	Output 1 functions
7.2	Output 2 functions
7.3	Choice of the function and the range of current output n.1
7.4	Choice of the function and the range of current output n.2
7.5	Full Scale value for analog out1
7.6	Full Scale value for analog out2

COMMUN.

MAIN MENU		
1	Sensor	
2	Units	
3	Scales	
4	Measure	
5	Alarms	
6	Inputs	
7	Outputs	
8	Communication	
9	Display	
10	Data logger	
11	Functions	
12		
13		
COMMUNICATION		
10	HART pr.	05
11	HART O. C.	ON
12	Dev. Addr	001
13	Speed=bps	9600
	Parity=	NO
	Delay=ms	00
	C. timeout	2

8.1	HART packet byte preambles
8.2	HART bus output control
8.3	Device communication address number
8.4	MODBUS link speed
8.5	MODBUS link parity
8.6	MODBUS reply delay
8.7	Maximum delay between chars (frames) MODBUS



DISPLAY

MAIN MENU		
1	Sensor	
2	Units	
3	Scales	
4	Measure	
5	Alarms	
6	Inputs	
7	Outputs	
8	Communication	
9	Display	
10	Data logger	
11	Functions	
12		
13		
DISPLAY		
	Language	EN
	Contrast	5
	Disp.time=s	020
	D.rate=Hz	5
	Disp. Fn.	1
	Disp.lock	ON
	Part. Tot	ON
	Neg. Tot.	ON
	Net tot.	ON
	Disp.date	ON
	Quick start	ON

9.1	Choice of the language
9.2	Display contrast
9.3	Display/keyboard inactivity time
9.4	Display updating frequency: 1-2-5-10 Hz
9.5	Display function number
9.6	Display function selection lock
9.7	Partial totalizer enable
9.8	Negative totalizer enable
9.9	Net totalizer enable
9.10	Time and date display enable
9.11	Quick start menu visualization

DATA LOGGER

DATA LOGGER

D.logger en.	ON	10.1	Data logger enabling
Meas. units	ON	10.2	Measure units recording enable
Field separat.	;	10.3	Field separator character
Decimal separat.	.	10.4	Decimal separator character
Interv.	01:01:00	10.5	Sampling interval
Log T+	ON	10.6	Enable logging of total direct totalizer
Log P+	ON	10.7	Enable logging of partial direct totalizer
Log T-	ON	10.8	Enable logging of total reverse totalizer
Log P-	ON	10.9	Enable logging of partial reverse totalizer
Log TN	ON	10.10	Enable logging of total net totalizer
Log PN	ON	10.11	Enable logging of partial net totalizer
Log Q (UM)	ON	10.12	Enable logging of flow rate in measure unit
Log Q (%)	ON	10.13	Enable logging of flow rate in percentage
Log AL.EV	ON	10.14	Enable logging of alarm events
Log STR	ON	10.15	Enable logging of sensor test results
Log BTS	ON	10.16	Enable logging of board temperature
Log IBV	ON	10.17	Enable logging of internal board voltage
Log EDC	ON	10.18	Enable logging of electrodes DC voltage
Log EAC	ON	10.19	Enable logging of electrodes AC voltage
Log EIZ	ON	10.20	Enable logging of electrodes impedance
Log SCU	ON	10.21	Enable logging of sensor coils value

```

M
10-Data logger
11-Functions
12-Diagnostic
13-System
9-Display
8-Communication
7-Outputs

```

FUNCTIONS

FUNCTIONS

T+ reset		11.1	Execute immediate reset of total direct totalizer
P+ reset		11.2	Execute immediate reset of partial direct totalizer
T- reset		11.3	Execute immediate reset of total reverse totalizer
P- reset		11.4	Execute immediate reset of partial reverse totalizer
Load Sens. F. def		11.5	Load sensor factory default
Load Conv. F. def		11.6	Load converter factory default
Save Sens. F. def		11.7	Save sensor factory default values
Save Conv. F. def		11.8	Save converter factory default values
Calibration		11.9	Execute immediate internal circuit calibration

```

M
11-Functions
12-Diagnostic
13-System
9-Display
8-Communication
7-Outputs

```

DIAGNOSTIC

DIAGNOSTIC

Self test		12.1	Self test diagnostic function
Test display		12.2	Function tests physical display
Sens. verify		12.3	Sensor verify diagnostic function
Flow sim. =	ON	12.4	Flow rate simulation enabling
Display measures		12.5	Display internal measured value
Disp. Comm. Vars		12.6	Display comm. diagnostic values
Display graphs		12.7	Display measure as graphs
Gen. sens. set		12.8	Generic sensor parameters set
SD card info		12.9	Sd card status informations
Firmware info		12.10	Firmware version/revision
S/N=	999001	12.11	Board serial number
WT=	002:21:00 : 22	12.12	Total working time

```

M
12-Diagnostic
13-System
9-Display
8-Communication
7-Outputs

```

SYSTEM

```

SYSTEM
Dayl. Saving =          ON
Time zone =            h+01.00
2016/04/04-16:07
L1 code =              *****
L2 code =              *****
L3 code =              *****
L4 code =              *****
L5 code =              *****
L6 code =              *****
Restr. Access=         ON
010.011.012.013
010.011.012.014
255.255.255.000
HT                     0.96469
HS                     1.00000
HR                     1.00000
DAC1                   (°C)
DAC1                   (°C)
DAC2                   661
DAC2                   3327
Stand-by               3453
FW update              14718
13-1 Daylight saving time change
13-2 Localized time zone
13-3 System date and time
13-4 Access level 1 code
13-5 Access level 2 code
13-6 Access level 3 code
13-7 Access level 4 code
13-8 Access level 5 code
13-9 Access level 6 code
13-10 Restricted access level
13-11 Device IP network address
13-12 Client IP network address
13-13 Network mask
13-14 Calibration coefficient KT
13-15 Calibration coefficient KF
13-16 Calibration coefficient KR
13-17 DAC1 out 4mA calibration point
13-18 DAC1 out 20mA calibration point
13-19 DAC2 out 4mA calibration point
13-20 DAC2 out 20mA calibration point
13-21 Stand-by
13-22 firmware update

MAI
10-Data logger
11-Functions
12-Diagnostic
13-System
    
```

ACCURACY

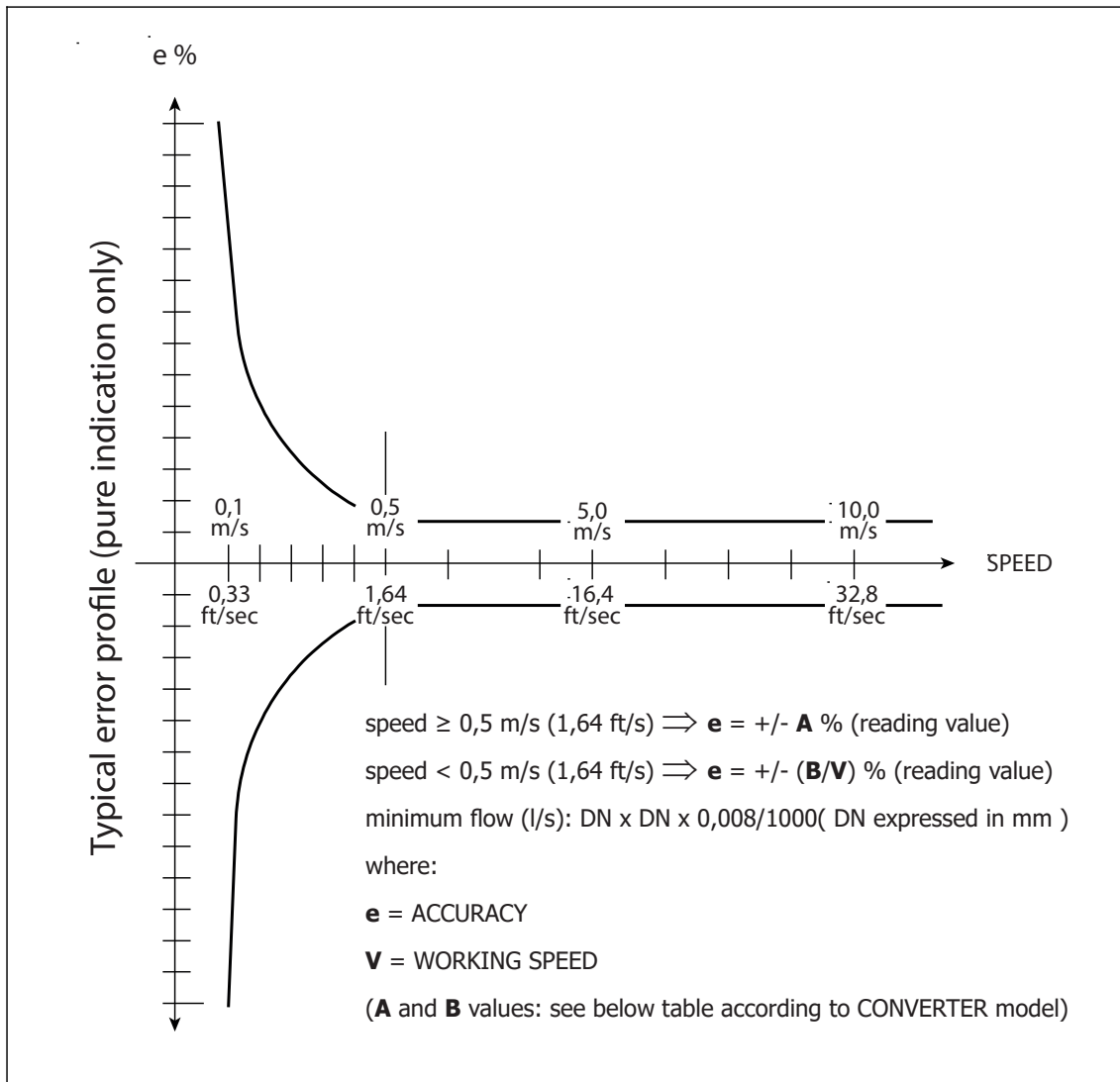

Full bore sensor

MS501/MS1000/MS2410/MS2500			MS 600			MS5000		
A	B(m/s)	B(ft/s)	A	B(m/s)	B(ft/s)	A	B(m/s)	B(ft/s)
0,2	0,1	0,66	0,4	0,2	1,32	2	1	3,28

Insertion sensors

See sensors DATA SHEET

Reference conditions below and as per internal testing procedures:

- Constant flow rate during the test
- Pressure: >30 Kpa
- Flow condition : fully developed flow profile
- Zero stability $\pm 0,005 \%$

HOW TO ORDER

CODE/ EXAMPLE	CODE/DESCRIPTION	
Display		
A	A	Blind version (without display and programming keys, cable USB type A/USB MINI B is REQUIRED TO PROGRAMMING)
	B	Graphic LCD WSTN - B/W - back light display, point matrix 128 x 64, 8 line/16 characters and 3 programming keys (mandatory for MI001)
Housing material / Protection rate		
0	0	Nylon PA6 with fiber glass, protection rate IP 67
	1	Painted aluminum die casting, protection rate IP67
	2	Painted aluminum die casting, protection rate IP68 1,5 meters under water, Compact Version, n° 1 IP 68 MIL connector for power supply (CONNECTORS SUPPLIED: MALE + FEMALE)
	3	Painted aluminum die casting, protection rate IP68 1,5 meters under water, Compact Version, Complete of n° 1 of 10 poles IP68 MIL connector (outputs connections to be specified) and n° 1 IP 68 MIL connector for power supply (CONNECTORS SUPPLIED: MALE + FEMALE)
	4	Painted aluminum die casting, protection rate IP68 1,5 meters under water, Separate Version, Complete of n° 2 IP 68 MIL connectors for cables from the sensor and n° 1 IP 68 MIL connector for power supply (CONNECTORS SUPPLIED: MALE + FEMALE)
	5	Painted aluminum die casting, protection rate IP68 1,5 meters under water, Separate Version, Complete of n° 2 IP 68 MIL connectors for cables from the sensor, n° 1 of 10 poles IP68 MIL connector (outputs connections to be specified) and n° 1 IP 68 MIL connector for power supply (CONNECTORS SUPPLIED: MALE + FEMALE)
Version		
A	A	Compact version with sensor MS.... (liquid maximum temperature 100 °C)
	B	Separate version for wall mounting, complete with mounting accessories (CABLE C015/C016)
	C	Compact version with display visible from the top
Power supply		
1	1	Power supply : 100 ... 240 VAC 44/66 Hz
	2	Power supply : 24 ... 36 VAC/VDC 0...44/66 Hz
	3	Power supply : 12...48 VDC
	4	Power supply : 100 ... 240 VAC 44/66 Hz + 1 Rechargeable back-up Battery (the use of battery supports only the measure UP TO 15 days; all the outputs are set to OFF)
	5	Power supply : 24 ... 36 VAC/VDC 0...44/66 Hz + 1 Rechargeable back-up Battery (the use of battery supports only the measure UP TO 15 days; all the outputs are set to OFF)
	6	Power supply : 12...48 VDC + 1 Rechargeable back-up Battery (the use of battery supports only the measure UP TO 15 days; all the outputs are set to OFF)
	7	Power supply : 100 ... 240 VAC 44/66 Hz + n° 1 SETTINGS FOR Rechargeable back-up Battery (the Rechargeable Battery is NOT included)
	8	Power supply : 24 ... 36 VAC/VDC 0...44/66 Hz + n° 1 SETTINGS FOR Rechargeable back-up Battery (the Rechargeable Battery is NOT included)
	9	Power supply : 12...48 VDC + n° 1 SETTINGS FOR Rechargeable back-up Battery (the Rechargeable Battery is NOT included)
Analogue output		
A	A	Without Analogue output
	B	n° 1 Analogue output 0/4...20/22 mA (Hart optional)
	C	n° 2 Analogue outputs 0/4...20/22 mA (Hart optional over Out.1)
Digital Input/Output		
0	0	With Digital Input only
	1	With n° 1 PROGRAMMABLE Digital Output/n°1 Digital Input
	2	With n° 2 PROGRAMMABLE Digital output/n°1 Digital Input
Communication Gateway		
A	A	Without Gateway
	B	RS485 port - Protocol MODBUS required
	C	Hart (4/20 mA/ Analog OUT n° 1 is required)
	D	Wi-Fi (for programming)
	E	Others



Protocols		
0	0	Without Protocol
	1	Modbus (over RS485) requires RS485 port
Accuracy		
A	A	Standard accuracy 0,2 %
	C	Special accuracy (to be defined)
Data Logger		
0	0	Without Data Logger
	1	MicroSD Memory 4 GB : Data Logger + RTC (Real Time Clock)
	2	MicroSD Memory 4 GB : Data Logger + RTC (Real Time Clock) + BIV (Built In Verificator)
	3	MicroSD Memory 4 GB : Data Logger + RTC (Real Time Clock) + Meter Data (Real Time Converter & Sensor Data on SD Memory)
	4	MicroSD Memory 4 GB : Data Logger + RTC (Real Time Clock) + BIV + Meter Data
Special Features		
A	A	NONE
	B	WITH ANTICONDENSE CAP
	C	n° 5 CABLE GLAND 1/2" NPT - Nickel plated brass CODE 1.609.1200.70 (CABLE 6 - 12 mm)
	D	n° 5 HOLES FOR CABLE GLAND 1/2" NPT (WITHOUT CABLE GLAND)

Complete code
example for
order



MV210-A0A1A0A0A0A

ISOIL INDUSTRIA S.p.A.

HEAD OFFICE	SERVICE
Via Fratelli Gracchi, 27 20092 Cinisello Balsamo (MI) Tel +39 02 66027.1 Fax +39 02 6123202 sales@isoil.it	isomagservice@isoil.it

If you want to find the complete list of our distributors access at the following link:

<http://www.isoil.it/en>



Due to the constant technical development and improvement of its products, the manufacturer reserves the right to make changes and/or modify the information contained in this document without notice.